

ITS

Dual coil indirect calorifier

ITS - 300/400/500/600/750/1000



Indirect water heater (calorifier) for a wide range of applications

- Single-wall spiral heat exchanger
- PermaGlas Ultra Coat second-generation glass coating technology prevents corrosion
- Insulated ring base for easy installation
- Insulated access cover for comprehensive waterside maintenance
- Replaceable magnesium anode
- Options: Flexible magnesium anode for installation in confined areas
- Powered anode for reduced maintenance requirements
- Temperature and pressure valve with stainless-steel spring set to 95°C and a maximum water pressure of (10 bar) 1000kPa
- Analogue temperature gauge (0-120°C)
- Electric element heat packs (3 - 36 kW)
- Unvented kits
- Destratification pump kit

Technical specifications

		ITS 300	ITS 400	ITS 500	ITS 600	ITS 750	ITS 1000
Technical data							
Output solar coil	kW	46	52	68	72	80	87
Surface area solar coil	m ²	1.45	1.64	2.13	2.39	2.66	2.89
Water capacity solar coil	l	9.5	9.9	12.8	20.3	22.6	24.6
Flow rate solar coil (80-60°C)	l/h	1978	2236	2924	3096	3440	3741
Pressure drop solar coil	mbar	44	78	166	37	50	61
Output primary coil	kW	27	37	42	40	56	58
Surface area primary coil	m ²	0.85	1.15	1.31	1.33	1.86	1.93
Water capacity primary coil	l	5.7	6.9	7.9	11.3	15.8	16.4
Flow rate primary coil (80-60°C)	l/h	1161	1591	1806	1720	2408	2494
Pressure drop primary coil	mbar	12	30	43	7	18	20
Maximum working pressure tank	kPa (bar)	1000(10)	800(8)	800(8)	800(8)	800(8)	800(8)
Maximum working pressure coil	kPa (bar)	2500(25)	1600(16)	1600(16)	1600(16)	1600(16)	1600(16)
Maximum operating temperature tank	°C	95					
Maximum operating temperature coil	°C	160	110	110	110	110	110
Standby loss	kWh/24h	1.32	1.60	1.88	1.85	2.03	2.19
Draw-off capacity							
Tcold = 10°C/Tset = 80°C							
Storage capacity	l	300	382	470	641	718	1007
Based only on primary coil							
30 min. ΔT=44°C	l	414	559	657	743	931	1125
60 min. ΔT=44°C	l	678	920	1067	1134	1478	1692
90 min. ΔT=44°C	l	942	1282	1477	1525	2026	2259
120 min. ΔT=44°C	l	1206	1644	1888	1916	2573	2826
Continuous ΔT=44°C	l/h	528	723	821	782	1095	1134
Heating-up time ΔT=44°C	min.	33	32	34	49	39	53
30 min. ΔT=50°C	l	364	492	578	654	819	990
60 min. ΔT=50°C	l	597	810	939	998	1301	1489
90 min. ΔT=50°C	l	829	1128	1300	1342	1783	1988
120 min. ΔT=50°C	l	1061	1446	1661	1686	2264	2487
Continuous ΔT=50°C	l/h	464	636	722	668	963	998
Heating-up time ΔT=50°C	min.	37	36	39	56	45	61
30 min. ΔT=55°C	l	331	447	525	595	745	900
60 min. ΔT=55°C	l	542	736	854	907	1183	1354
90 min. ΔT=55°C	l	753	1026	1182	1220	1621	1807
120 min. ΔT=55°C	l	965	1315	1510	1533	2058	2261
Continuous ΔT=55°C	l/h	442	597	657	625	876	907
Heating-up time ΔT=55°C	min.	41	40	43	61	49	67
Based on both coils. This is not always possible							
30 min. ΔT=44°C	l	1010	1269	1566	1801	2110	2557
60 min. ΔT=44°C	l	1723	2139	2641	2895	3439	3974
90 min. ΔT=44°C	l	2437	3009	3716	3990	4768	5391
120 min. ΔT=44°C	l	3150	3878	4791	5085	6097	6808
Continuous ΔT=44°C	l/h	1427	1740	2150	2189	2658	2834
Heating-up time ΔT=44°C	min.	12	13	13	18	16	21
30 min. ΔT=50°C	l	889	1117	1378	1585	1857	2250
60 min. ΔT=50°C	l	1517	1882	2324	2548	3026	3497
90 min. ΔT=50°C	l	2144	2648	3270	3511	4196	4744
120 min. ΔT=50°C	l	2772	3413	4216	4474	5366	5991
Continuous ΔT=50°C	l/h	1256	1531	1892	1926	2339	2494
Heating-up time ΔT=50°C	min.	14	15	15	20	18	24
30 min. ΔT=55°C	l	808	1015	1253	1441	1688	2046
60 min. ΔT=55°C	l	1379	1711	2113	2316	2751	3179
90 min. ΔT=55°C	l	1949	2407	2973	3192	3815	4313
120 min. ΔT=55°C	l	2520	3103	3833	4068	4878	5447
Continuous ΔT=55°C	l/h	1141	1392	1720	1751	2127	2267
Heating-up time ΔT=55°C	min.	15	16	16	22	20	27
Shipping data							
Weight empty	kg	133	145	196	246	262	340
Maximum weight	kg	422	527	666	887	980	1347
Weight incl. packaging	kg	144	156	207	257	273	352
Width packaging	mm	780	780	780	870	870	1010
Height packaging	mm	1510	1850	2150	1930	2150	2100
Depth packaging	mm	780	780	780	870	870	1010

Dimensions

ITS 300

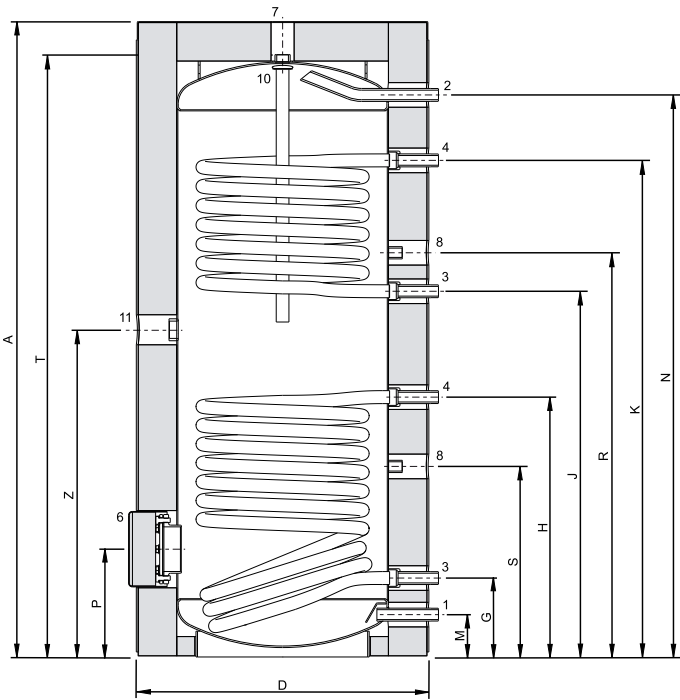

IMD-1282 R0

ITS 400-1000

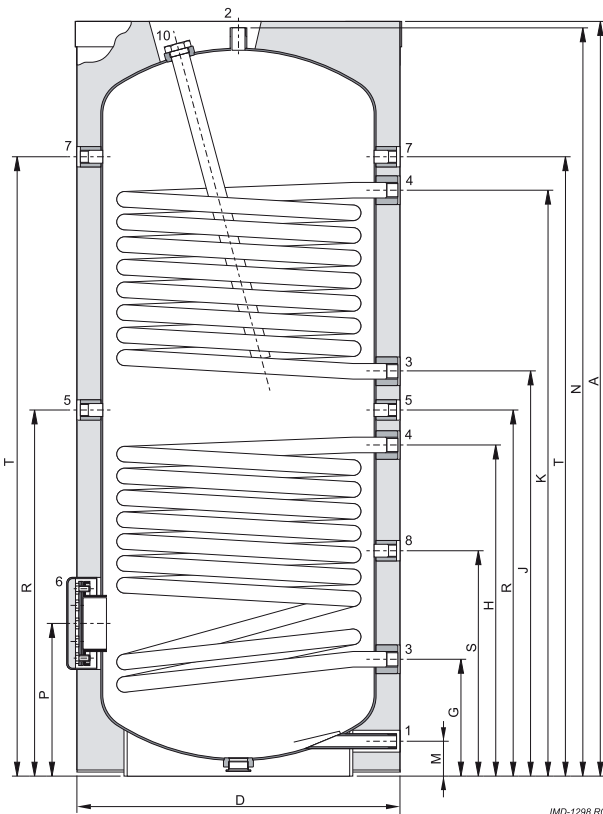

IMD-1298 R0

	ITS 300	ITS 400	ITS 500	ITS 600	ITS 750	ITS 1000
A Total height	mm 1650	1710	2045	1840	2035	2005
D Diameter (without insulation)	mm 550	600	600	750	750	900
Diameter (with insulation)	mm 750	740	760	910	930	1100
G Height heat exchanger outlet	mm 205	260	260	310	310	350
H Height heat exchanger inlet	mm 675	775	920	910	970	950
J Height heat exchanger outlet (on top)	mm 950	945	1090	1090	1150	1130
K Height heat exchanger inlet (on top)	mm 1290	1280	1470	1390	1570	1490
M Height cold water inlet	mm 110	70	70	85	85	95
N Height warm water outlet	mm 1460	1655	1995	1805	2000	1965
P Height inspection opening	mm 280	330	330	420	420	450
R Height connection circulation	mm 1050	860	1000	1000	1080	1040
S Height immersion well	mm 495	500	500	655	655	705
T Height T&P connection	mm 1545	1365	1700	1480	1875	1605
Z Height electrical element	mm 850	-	-	-	-	-
1 Cold water inlet	-	G 1" R 2"	R 1½" R 1½"	R 1½" R 1½"	R 1½" R 1½"	R 1½" R 1½"
2 Warm water outlet	-	G 1" R 2"	R 1½" R 1½"	R 1½" R 1½"	R 1½" R 1½"	R 1½" R 1½"
3 Heat exchanger outlet	-	G 1" Rp 1"	Rp 1" Rp 1¼"	Rp 1¼"	Rp 1¼"	Rp 1¼"
4 Heat exchanger inlet	-	G 1" Rp 1"	Rp 1" Rp 1¼"	Rp 1¼"	Rp 1¼"	Rp 1¼"
5 Connection circulation	-	Rp ¾"	Rp ¾" Rp ¾"	Rp ¾" Rp ¾"	Rp ¾" Rp ¾"	Rp ¾" Rp ¾"
6 Diameter inspection opening	mm 110	115	115	180	180	180
7 T&P connection	-	Rp 1" Rp ¾"	Rp ¾" Rp ¾"	Rp ¾" Rp ¾"	Rp ¾" Rp ¾"	Rp ¾" Rp ¾"
8 Immersion well	-	Rp ¾" Rp ¾"	Rp ¾" Rp ¾"	Rp ¾" Rp ¾"	Rp ¾" Rp ¾"	Rp ¾" Rp ¾"
10 Anode connection	-	G 1¼" Rp 1¼"	Rp 1¼" Rp 1¼"	Rp 1¼" Rp 1¼"	Rp 1¼" Rp 1¼"	Rp 1¼" Rp 1¼"
11 Electrical element connection	-	G 1½"	-	-	-	-

Energy labeling

	ITS 300	ITS 400	ITS 500	ITS 600	ITS 750	ITS 1000
Load Profil	-	C	C	C	-	-
Standby loss	W	92	100	104	126	146

Installation diagrams

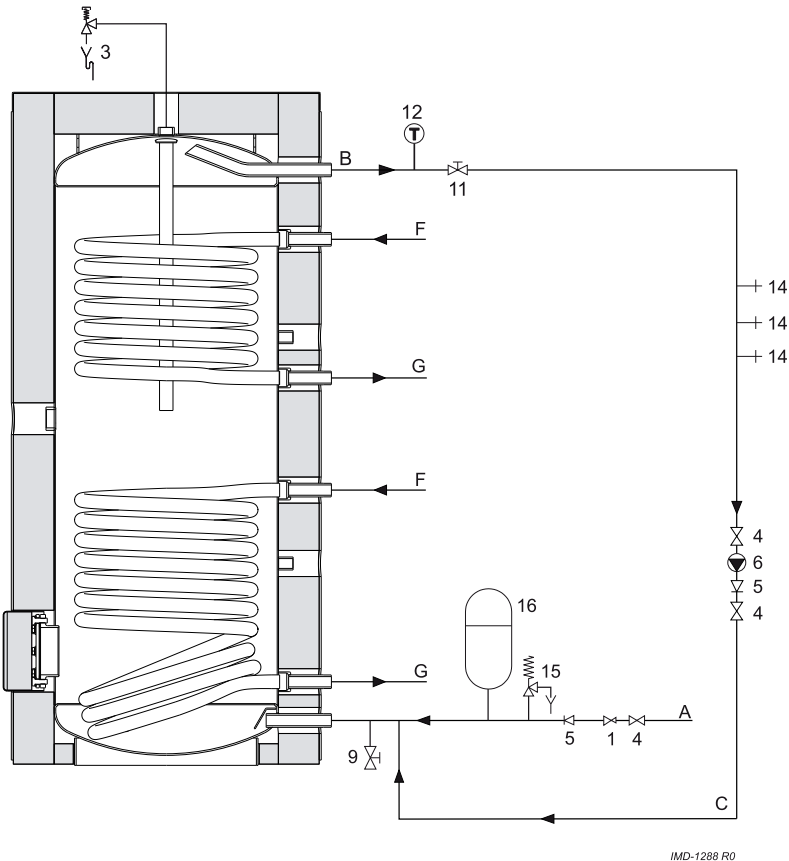

- 1 Pressure reducing valve
- 3 T&P valve
- 4 Stop valve
- 5 Non-return valve
- 6 Circulation pump
- 9 Drain valve
- 11 Service valve
- 12 Temperature meter
- 14 Hot water tap
- 15 Expansion valve
- 16 Expansion vessel
- 17 Three way valve
- 18 Water cistern
- 19 Float valve

- A Cold water supply
- B Hot water outlet
- C Circulation pipe
- F Primary flow
- G Primary return
- E Over flow pipe
- H Expansion pipe

A.O. Smith unvented system kits utilise combination valves.

In the instruction manual you will find all the necessary information regarding connection, installation and maintenance of the product; including information on the electrical connections.

Information regarding the recycling or disposal of the product can also be found in the manual. This manual is delivered with the appliance and can also be found on our website; www.aosmith.co.uk.