



Instano

Wall-mounted condensing instantaneous water heater

ICW-25/35/60



Maximum working pressure 10 bar • Energy efficient, modulating burner • High-efficiency **96%** (gross) • Stainless steel heat exchangers • Low NOx • Maximum set point 75°C • Equipped with a LCD display with stand-by option • Displays water temperature, self-diagnostics of components and options • Electronic ignition • Small foot print and easy to handle due to low weight • Room-sealed product • Suitable for natural gas and propane

Features and options

- Maximum working pressure 10 bar
- Energy efficient, modulating burner
- High-efficiency 96% (gross)
- Stainless steel heat exchangers
- Low NOx
- Maximum set point 75°C
- Equipped with a LCD display with stand-by option
- Displays water temperature, self-diagnostics of components and options
- Electronic ignition
- Small foot print and easy to handle due to low weight
- Room-sealed product
- Suitable for natural gas and propane

Ecodesign specifications

		ICW-25	ICW-35	ICW-60
Nitrogen oxide emission (NO2) *	mg/kWh	31	25	28
Noise level inside	dB(A)	59	61	66
Load profile	-	XL	XXL	XXL
Energy efficiency class	-	A	A	A
Efficiency *	%	90	92	88
Daily electricity consumption	kWh	0.276	0.249	0.280
Daily fuel consumption *	kWh	20.917	26.160	27.205
Annual electricity consumption	kWh/year	61	55	61
Annual fuel consumption *	GJ/year	16	21	22
Other load profile	-	-	XL	-
Energy efficiency class	-	-	A	-
Efficiency *	%	-	89	-
Daily electricity consumption	kWh	-	0.225	-
Daily fuel consumption *	kWh	-	21.293	-
Annual electricity consumption	kWh/year	-	49	-
Annual fuel consumption *	GJ/year	-	16	-

* Gross, Based on G20

Technical specifications

		ICW-25	ICW-35	ICW-60
Gas data natural gas 2H (G20)				
Input *	kW	28.3	35.5	64.2
Output	kW	27.0	33.5	60.9
Gas consumption **	m ³ /h	2.7	3.4	6.1
inlet pressure	mbar	20	20	20
Gas data propane 3B/P (G31)				
Input *	kW	28.3	35.5	64.2
Output	kW	27.0	33.5	60.9
Gas consumption **	m ³ /h	2.0	2.5	4.5
inlet pressure	mbar	37	37	37
General				
Efficiency (gross value)	%	96	95	96
Empty weight	kg	36	36	48
Maximum temperature setting	°C	75	75	75
Maximum working pressure	kPa (bar)	1000 (10)		
Draw-off capacity ***				
Continuous $\Delta T=28^{\circ}\text{C}$	ltr./h.	829	1029	1871
	ltr./min.	13.8	17.1	31.2
Continuous $\Delta T=50^{\circ}\text{C}$	ltr./h.	464	576	1047
	ltr./min.	7.7	9.6	17.5
Continuous $\Delta T=65^{\circ}\text{C}$	ltr./h.	357	443	806
	ltr./min.	6.0	7.4	13.4
Minimum draw-off rate	ltr./min.	2.5	2.5	2.5
Electrical data				
Power consumption	W	169	162	235
Power supply	VAC/Hz	230 (-15+10%)/50 (+/-1Hz)		
Transport data				
Weight incl. packaging	kg	37	37	49
Width packaging	mm	525	525	525
Height packaging	mm	900	900	900
Depth packaging	mm	350	350	515

* Gas data on gross value

** Gas consumption at 15°C and 1013.25 mbar

*** Based on natural gas

Dimensions

			ICW-25	ICW-35	ICW-60
A	Height	mm	800	800	815
B	Width	mm	445	445	445
C	Depth	mm	305	305	485
1	Cold water (external)	-	3/4"	3/4"	1"
2	Hot water (external)	-	1"	1"	1"
3	Gas control (external)	mm	3/4"	3/4"	3/4"
4	Condensation drainage (external)	-	20	20	20
5	Circulation (internal)	-	3/4"	3/4"	3/4"
6	Flue connection	mm	60/100	60/100	80/125

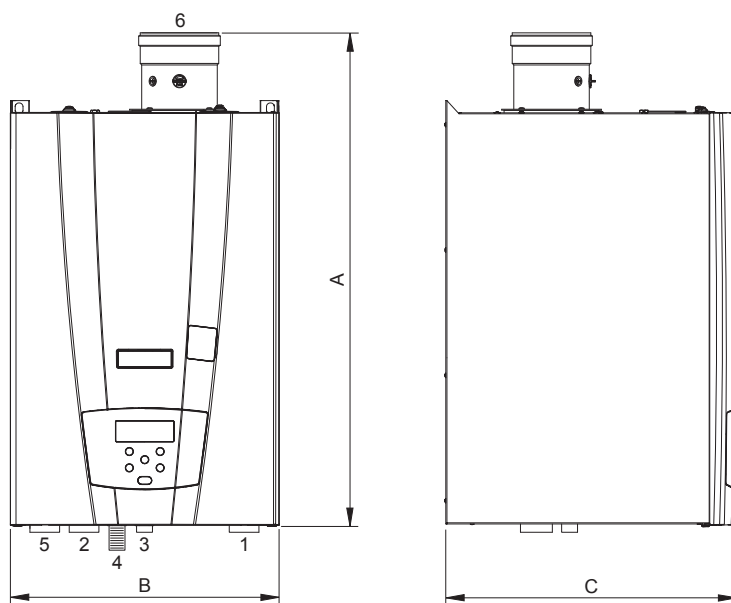

Installation drawing

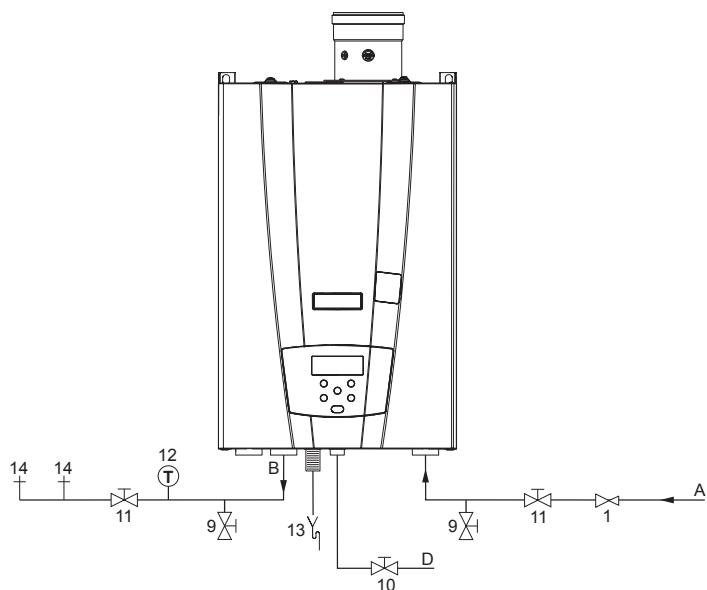

- 1 Pressure reducing valve
- 9 Drain valve
- 10 Gas valve
- 11 Service valve
- 12 Temperature meter
- 13 Condense drain
- 14 Hot water tap

- A Cold water supply
- B Hot water outlet
- D Gas supply

In the instruction manual you will find all the necessary information regarding connection, installation and maintenance of the product; including information on the electrical connections.

Information regarding the recycling or disposal of the product can also be found in the manual. This manual is delivered with the appliance and can also be found on our website; www.aosmithinternational.com.

Installation options

	ICW-25	ICW-35	ICW-60
Concentric			
Diameter (mm)	60/100	60/100	80/125
Max. length (m)	10	10	10
Lequivalent/bend 90° (m)	1	1	1
Lequivalent/bend 45° (m)	0.5	0.5	0.5
Parallel			
Diameter (mm)	(2x) 80	(2x) 80	(2x) 80
Max. length (m)	(2x) 20	(2x) 12.5	(2x) 5
Lequivalent/bend 90° (m)	1	1	1
Lequivalent/bend 45° (m)	0.5	0.5	0.5

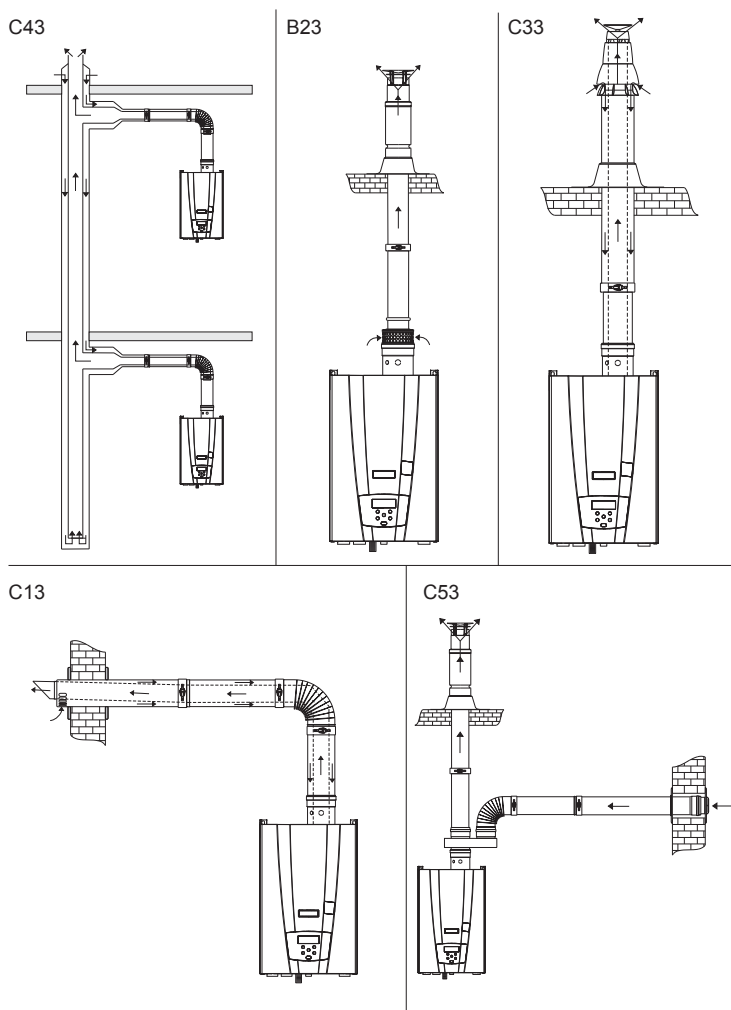

Parallel system (80mm/80mm)		
Adapter PP/Alu 60/100mm --> 2x 80mm	0312273	
Adapter PP/Alu 80/125mm --> 2x 80mm	0312209	
Roof flue terminal (incl. transition piece)	0310708	
Wall flue terminal (incl. transition piece)	0310728	
Tube	L = 250 mm	0310718
	L = 500 mm	0310719
	L = 1000 mm	0310720
	L = 2000 mm	0310721
	Telescopic (240-360 mm)	0310722
Bend concentric	Angle = 45°	0310701
	Angle = 90°	0310702

Concentric system (80/125mm)		
Roof flue terminal	0310753	
Wall flue terminal	0310757	
Tube concentric	L = 250 mm	0310740
	L = 500 mm	0310741
	L = 1000 mm	0310742
	L = 2000 mm	0310743
	Telescopic (280-395 mm)	0310744
Bend concentric	Cut to length	0310745
	Angle = 45°	0310734
	Angle = 90°	0310735
Wall flue terminal plate	0302520	
Roof tile flue terminal - Angle 25-45°	0303506	

Concentric system (60/100mm)		
Roof flue terminal	0312246	
Wall flue terminal	0312247	
Tube concentric	L = 250 mm	0312239
	L = 500 mm	0312240
	L = 1000 mm	0312241
	L = 2000 mm	0312242
	Telescopic	0312243
Bend concentric	Cut to length	0312244
	Angle = 45°	0312236
	Angle = 90°	0312237
Wall flue terminal plate Ø120mm	0307173	

B23 system	
Air inlet basket 60/100	0312446
Air inlet basket 80/125	0305030

Further information on the flue gas discharge materials can be found in the Installation Manual.

Data subject to change UK Adveco/1016/Instano/01
Terms and conditions apply, please refer to our website