

Twister

Condensing Stainless Steel Water Heater

TWI 35-130/45-190



Fully room-sealed condensing high-efficiency water heater (95% gross)

- Stainless steel tank
- No anodes simplify maintenance
- Premix Low-NOx burner saves the environment
- Whisper quiet operation
- Specially designed blower and burner minimise noise
- Plug-and-Play technology; connect air inlet, exhaust outlet, water, electricity, and gas, set the temperature and the system functions properly
- Three external LED lights indicate operational status of water heater
- Full serviceability from the front
- Suitable for natural gas and propane

Features and options

- Fully room-sealed condensing high-efficiency water heater (95% gross)
- Stainless steel tank
- No anodes simplify maintenance
- Premix Low-NOx burner saves the environment
- Whisper quiet operation
- Specially designed blower and burner minimise noise
- Plug-and-Play technology; connect air inlet, exhaust outlet, water, electricity, and gas, set the temperature and the system functions properly
- Three external LED lights indicate operational status of water heater
- Full serviceability from the front
- Suitable for natural gas and propane

Ecodesign specifications

		TWI 35-130	TWI 45-190
Energy labeling (G20)			
Load Profil	-	XXL	XXL
Energy labeling	-	A	A
Efficiency	%	88	87
Annual Electricity Consumption (AEC)	kWh	135	139
Daily Electricity Consumption	kWh	0.615	0.636
Annual Fuel Consumption (AEC)	GJ GCV	21	21
Daily Fuel Consumption	kWh GCV	26.476	26.550
Nitrogen Dioxide Emission (NO2)	mg/kWh GCV	48	62
Mixed Water of 40°C (according V40)	ltr.	∞	∞
Sound Power Level	dB	64	68

Technical specifications

		TWI 35-130	TWI 45-190
Gas data natural gas 2H (G20)			
Input*	kW	37.8	50.0
Output	kW	36.0	47.7
Inlet pressure	mbar	20	20
Gas consumption**	m ³ /h	3.6	4.8
Flue gas discharge	kg/h	61.2	78.6
Gas data propane 3P (G31)			
Input*	kW	37.0	48.9
Output	kW	36.0	47.7
Inlet pressure	mbar	37	37
Gas consumption**	kg/h	2.6	3.5
Flue gas discharge	kg/h	63.8	81.4
General			
NOx-value	ppm	49	29
Noise level	dB	51	58
Efficiency (gross)	%	95	95
Weight empty	kg	70	82
Maximum weight	kg	199	271
Storage capacity	l	129	189
Max. temperature setting	°C	85	85
Maximum working pressure	kPa (bar)		800 (8)
Draw-off capacity			
T_{cold} = 10°C / T_{set} = max. temp. setting			
30 min. ΔT=44°C	l	450	670
60 min. ΔT=44°C	l	800	1200
90 min. ΔT=44°C	l	1200	1600
120 min. ΔT=44°C	l	1500	2100
Continuous ΔT=44°C	l/h	710	940
Heating-up time ΔT=44°C	min.	11	12
30 min. ΔT=50°C	l	380	580
60 min. ΔT=50°C	l	690	990
90 min. ΔT=50°C	l	1000	1400
120 min. ΔT=50°C	l	1400	1900
Continuous ΔT=50°C	l/h	620	820
Heating-up time ΔT=50°C	min.	12	14
30 min. ΔT=55°C	l	340	520
60 min. ΔT=55°C	l	620	890
90 min. ΔT=55°C	l	900	1300
120 min. ΔT=55°C	l	1200	1700
Continuous ΔT=55°C	l/h	570	750
Heating-up time ΔT=55°C	min.	14	15
Electrical data			
Power consumption	W	200	300
Power supply	VAC/Hz	230 (-15+10%)/50 (+/-1Hz)	
Shipping data			
Weight incl. packaging	kg	88	100
Height packaging	mm	1400	1750
Width packaging	mm	780	780
Depth packaging	mm	870	870

* Gas data on gross value

** Gas consumption at 15°C and 1013.25 mbar

Dimensions

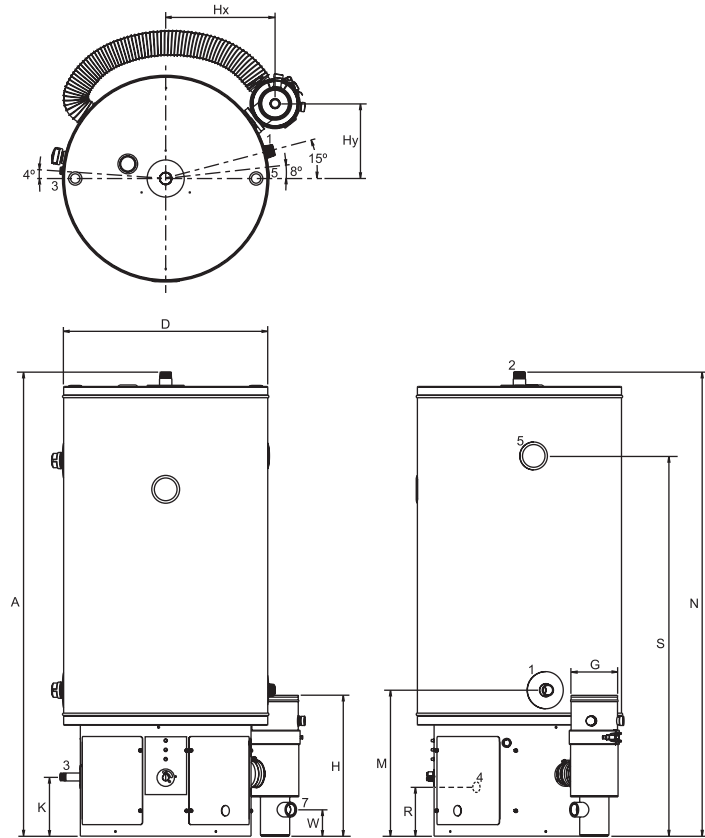

	TWI 35-130	TWI 45-190
A	1270	1655
D	560	560
G	80/125	80/125
H	385	385
Hx	300	300
Hy	205	205
K	160	160
M	400	400
N	1270	1655
R	155	155
S	1040	1395
W	100	100
1	Cold water	1-11.5 NPT
2	Hot water	1-11.5 NPT
3	Gas control	1/2-14 NPT (TWI 45-190 3/4-14 NPT)
4	Tank drain valve	3/4-14 NPT
5	T&P valve	1-11.5 NPT
7	Condensation drainage	Rp1

Dimensions in mm.



Installation diagrams

Vented

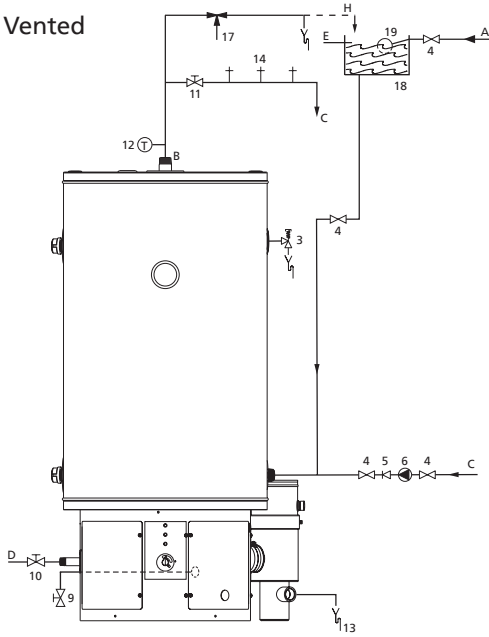

- 1 Pressure reducing valve
- 3 T&P valve
- 4 Stop valve
- 5 Non-return valve
- 6 Circulation pump
- 9 Drain valve
- 10 Gas valve
- 11 Service valve
- 12 Temperature meter
- 13 Condensate drain
- 14 Hot water tap
- 15 Expansion valve
- 16 Expansion vessel
- 17 Three way valve
- 18 Water cistern
- 19 Float valve

- A Cold water supply
- B Hot water outlet
- C Circulation pipe
- D Gas supply
- E Overflow pipe
- H Expansion pipe

A.O. Smith unvented system kits utilise combination valves.

In the instruction manual you will find all the necessary information regarding connection, installation and maintenance of the product; including information on the electrical connections.

Information regarding the recycling or disposal of the product can also be found in the manual. This manual is delivered with the appliance and can also be found on our website; www.aosmith.co.uk.

Unvented

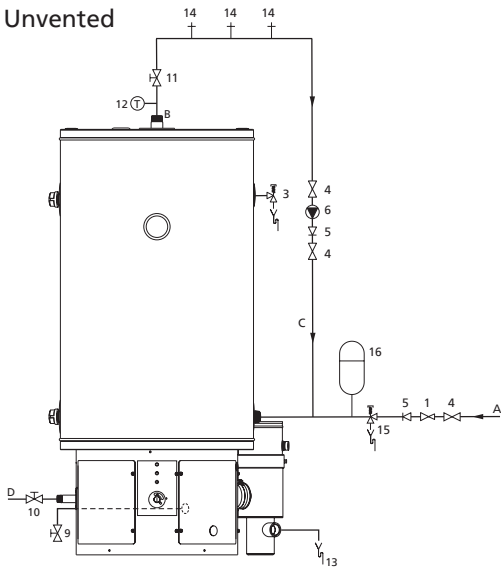

Installation options

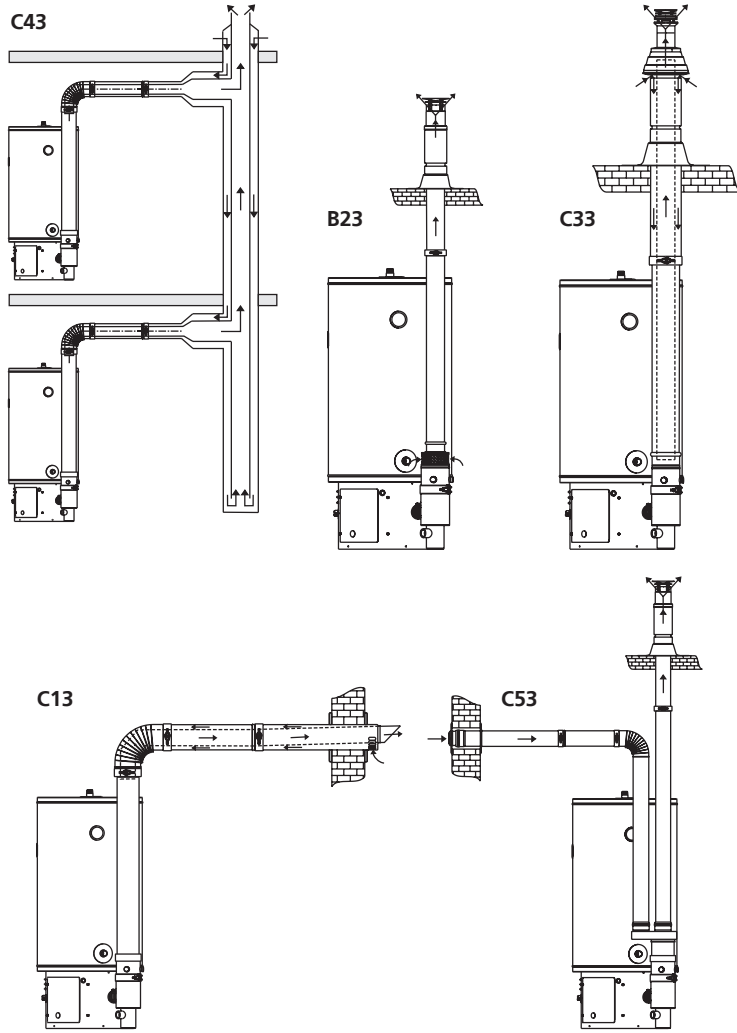

Further information on the flue gas discharge materials can be found in the Installation & Commissioning Manual.

A Twister water heater should be installed according category B23, C13, C33, C43 or C53*.

	TWI 35-130 Ø80/125	TWI 45-190 Ø80/125
Concentric		
Diameter (mm)	80/125	80/125
Max. length (m)	20	20
Max. 45/90° bend	5	5
Parallel (standard diameter)		
Diameter (mm)	80	80
Max. length (m)	30	20
Lequivalent/bend 90° (m)	3.9	3.9
Lequivalent/bend 45° (m)	1.1	1.1
Parallel (larger diameter for more length)		
Diameter (mm)	100	100
Max. length (m)	100	75
Lequivalent/bend 90° (m)	4.6	4.6
Lequivalent/bend 45° (m)	1.2	1.2
* All Twisters are also approved for installations where the unit is supplied without venting materials (C63).		
Concentric flues		
It is not permitted to use more than the specified number of bends, even when the duct is shorter than the maximum length. A 45° bend is equivalent to a 90° bend.		
Parallel flues		
- The maximum permissible length should be reduced by the equivalent length of each bend. (Note: for a parallel installation this means that 3 changes in direction amount to 6 bends (3 in the supply duct and 3 in the flue).		
- The maximum length also applies if a parallel installation has different supply and flue duct lengths (B23, C53)).		
- Combined flues (C43) shall be fitted with a condensate drain.		
Note: horizontal flue runs must be installed with a fall of at least 5 mm per metre towards the heater.		

Minimum space requirements

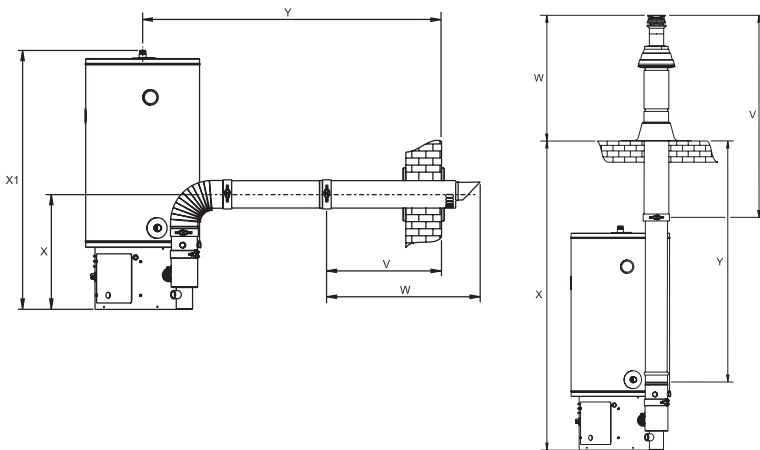

	TWI 35-130 Ø80/125	TWI 45-190 Ø80/125
Minimal space for wall duct (mm)		
V	550	550
W	725	725
X	530	530
X*	980	980
X1	1270	1620
Y	1495	1495
Y*	1045	1045
Minimal space for roof duct (mm)		
V	1305	1305
W	680	680
X	1960	1960
Y	1575	1575

* Distance without concentric pipe between bend and wall duct.

Data subject to change UK/0216/TWI/03
Terms and conditions apply, please refer to our website.