

TWI II from 01-05-'19

TWI II parts



No.	Description	date	TWI 35-200	TWI 45-200
1	Sensor Kit		0313306(S)	0313306(S)
2	Pressure Switch		0324512(S)	0324512(S)
3	Burner and gasket		0313305(S)	0313305(S)
4	Blower and gasket		0313313(S)	0313313(S)
5	Spark Igniter with spark cable		0313304(S)	0313304(S)
6	Gas Valve		0313302(S)	0313302(S)
7	Control Board		0313552(S)	0313312(S)
8	Drain Valve		6907316 (S)	6907316 (S)
9	Fuse Holder		0313362(S)	0313362(S)
10	Fuse		0313361(S)	0313361(S)
11	Condensate Drain		0313290(S)	0313290(S)
12	Connector Venturi		0313291(S)	0313291(S)
13	Water Inlet tube		0313310(S)	0313310(S)
14	Air Inlet Filter		3710169 (S)	3710169 (S)
15	Sensor		0313301(S)	0313301(S)
16	ON/OFF-switch		0313309(S)	0313309(S)
17	Ignition Transformer with spark cable		0313311(S)	0313311(S)
18	Flame Rod		0313303(S)	0313303(S)
19	Display		0313308(S)	0313308(S)
20	Housing Display		0313307(S)	0313307(S)
21	Hose connector Drain Valve		0070065(S)	0070065(S)
	Gasket set with nuts & washers		0313377(S)	0313377(S)

TWI II accessories

Description	date	TWI 35-200	TWI 45-200
Conv. Set to LP		0313335(S)	0313335(S)
Conv. Set to NAT		0313336(S)	0313336(S)
Gas Cock		0300719(S)	0300719(S)
Inlet Security Group		0070066003(S)	0070066003(S)
Expansion Valve		0305712(S)	0305712(S)
T&P-valve NO WRAS		0306755(S)	0306755(S)

Parts that are marked yellow are parts that are used for maintenance.

Please check the serial number to determine the production date:

172406210302002

year week

Exploded view TWI II from 01-05-'19

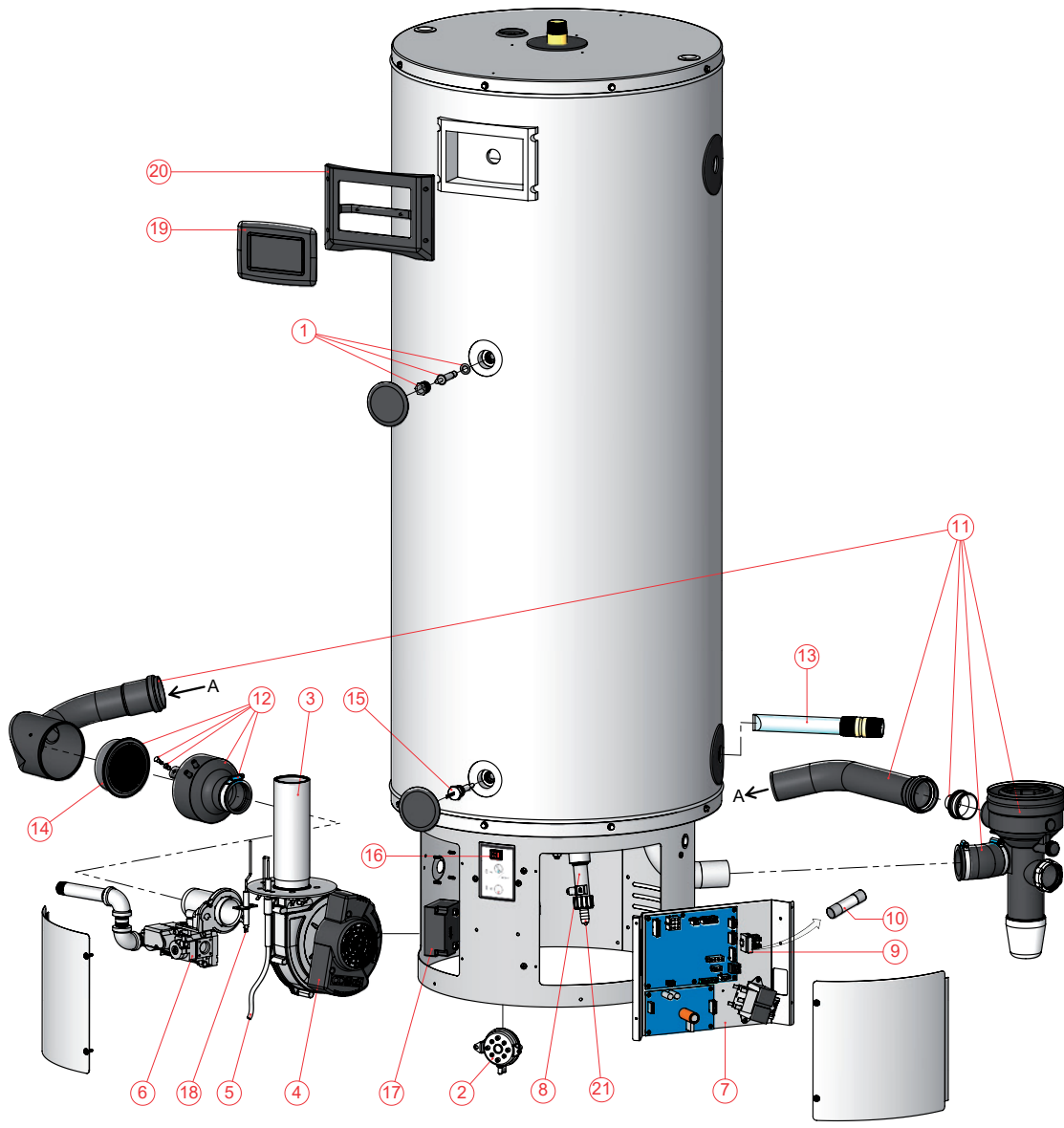

EVD-0111 R1